

schaerer
coffee comes to life

Coffee Soul

Makes the hearts of
restaurateurs beat faster



schaerer coffee soul

Barista inside

Pure temptation

Our love of coffee, our many years of coffee expertise and the skill of a barista are part of every Schaerer coffee machine. Espresso, cappuccino or latte macchiato – inside the coffee machines, all details interact perfectly to prepare beverages that are on par with the hand-made creations of a barista, both in terms of taste and appearance. Barista inside – for coffee and milk foam beverages no one can resist. ☕

PIONEER OF A NEW GENERATION

The Schaerer Coffee Soul unites an athletic yet elegant design with a number of refined technical features. It stands out thanks to its professional, gastronomical look and fits easily into any counter concept with its slim 33 centimetres. One-of-a-kind: You are sure to love Schaerer's own easy-to-use "Uptime!" descaling system.

A virtuoso coffee experience

You can effortlessly demonstrate the whole repertoire of coffee preparation on the Schaerer Coffee Soul and serve your guests the best coffee experience every time. The compact fully automatic coffee machine is based on a newly developed platform and offers advanced Schaerer technology packed in an exceptionally attractive restaurant-style design. The new 8" touch display draws all eyes to it. It whets the appetite for tasty coffee specialities and makes operation incredibly easy – for you and your employees or for self-service. With an output of up to 250 cups a day and the optional integrated Best Foam™ milk system, the Coffee Soul is a top-class coffee machine and is therefore ideal for discerning restaurants, bars or high-quality coffee provision in offices or premium vending services. ☒

Refined technical features

It's the little things that make the Schaerer Coffee Soul the real star on your counter. For example, the digital manometer displays the brewing pressure and underlines the athletic design of the coffee machine. Another special feature of the Coffee Soul: the milk pump is integrated in the coffee machine so you can decide whether to position the cooling unit on the left, on the right or under the Coffee Soul. Alongside the two bean hoppers with 1200 grams of capacity each, there is also room for the powder container on the coffee machine. ☒



CAPTIVATING COFFEE MACHINE TECHNOLOGY

Whether it is the revolutionary milk system, the brilliant touch display or the digital manometer – the equipment of the Schaerer Coffee Soul will make the hearts of restaurateurs beat faster!



Desire for variety

The Coffee Soul can be fitted with the patented Best Foam™ milk system as an option, allowing you to prepare barista-style hot and cold milk foam for top-quality milk-based coffee specialities. It provides maximum variety by allowing you to store 32 beverages, each of which can be configured with additional options – all via intuitive operation of the 8" touch display. Would you like to use the Coffee Soul for self-service? The display can be switched to a quick-selection programme for up to twelve beverages. Thanks to the attractive display and large symbols, everyone can prepare their favourite drink easily. ☑

Systematic descaling

The patent-pending Uptime! descaling system developed by Schaerer is a true innovation: it prevents scale-related malfunctions by prompting you to carry out the necessary descaling in good time. To use the system, simply insert a cartridge and start the descaling process. The coffee machine is ready for use again within a very short amount of time – when the descaling process is started at night, the machine is ready for service first thing in the morning, meaning it won't interrupt service. ☑

Clever cleaning

Like all Schaerer coffee machines, the Coffee Soul scores points with automatic cleaning programmes for the coffee and milk system. The mixing bowl is easy to clean as well: remove it completely, clean and reinsert – done. Furthermore, all key processes are visualised with an animated user support display to make operation even easier. The bean hoppers and powder containers attached to the machine can simply be removed for cleaning. A central locking mechanism prevents the coffee beans from pouring out. ☑

M2M Coffee Link

The Coffee Soul can be equipped with the Schaerer M2M Coffee Link telemetry solution in order to evaluate all relevant data regarding machine state, product supply, beverage statistics, extraction times, etc. It is also one of the first Schaerer coffee machines equipped for bi-directional data transmission. This enables location-independent access, for example to adjust recipes and extraction times or to start price campaigns on several coffee machines at the same time from a central location. ☑

YOUR ORCHESTRA FOR THE BEST COFFEE EXPERIENCE

8" touch display
Attractive beverage
display and intuitive user guide

Integrated
powder system
No additional-
module required

Flexible
milk cooling
Side cooling unit on the right,
left or under the counter

Milk temperature
sensor
Alarm function for perfect milk
temperature and food safety

Best Foam™
For hot and cold milk foam as
if it were made by a barista

Digital
manometer
Displays the
brewing pressure



Innovative Uptime!
descaling system
Simple descaling without any
unscheduled interruptions to service

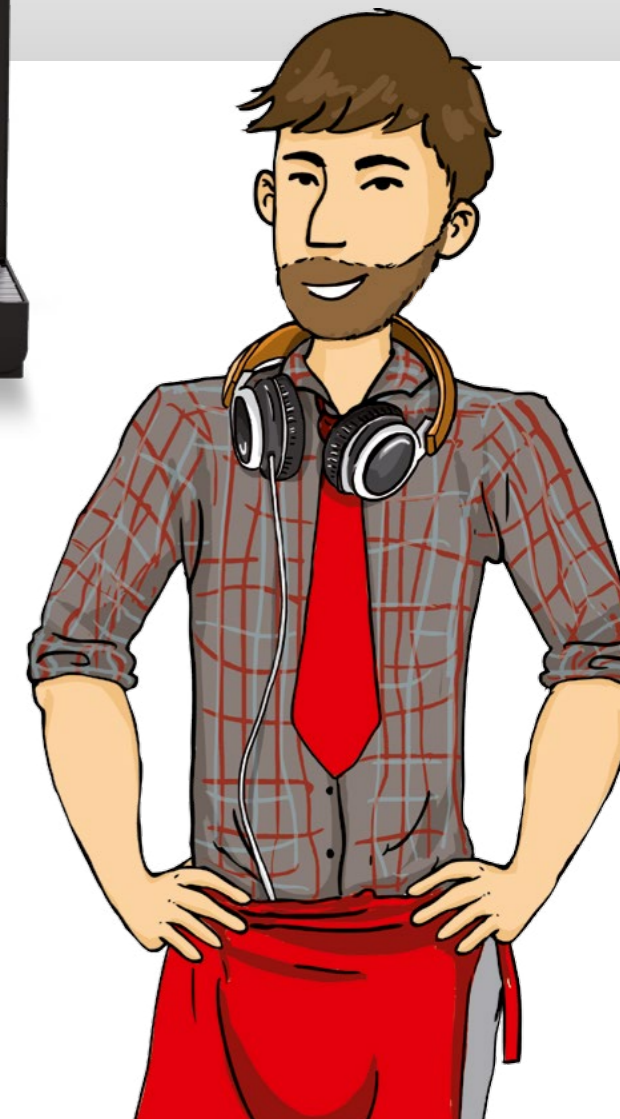

Why should you choose the Coffee Soul?

The Coffee Soul in restaurants and coffee bars

- Compact width of just 33 cm – ideal for small counters.
- Maximum variety and top beverage quality thanks to Best Foam™ and the option of storing up to 200 different drink configurations.
- Large coffee bean hopper with capacity of 1200 grams for 150 to 300 coffee beverages.
- Powder system with container for chocolate or milk powder for up to 70 beverages.
- Grounds container for approx. 60-70 grounds cakes.

The Coffee Soul for self-service

- Display: Intuitive user guidance with quick-selection programme for up to twelve beverages.
- Operator can set the beverage strength (barista key).
- One cup position for all beverages. Separate outlets prevent contamination of the beverages.
- Large ergonomic handle on the outlet for comfortable, continuous height adjustment.
- Lockable front panel prevents access by third parties.
- Robust design.
- Compatible with all common payment systems, on request.

The Coffee Soul for offices and premium vending

- Top beverage quality for premium vending using fresh milk.
- Display: Intuitive user guidance with quick-selection programme for up to twelve beverages.
- Can be extended with Schaefer's M2M Coffee Link telemetry solution.
- Easy to clean: Automatic cleaning programme for coffee, milk and powder system.
- Easy supply/filling.
- Milk temperature sensor for maximum food safety. Shown on display and in M2M Coffee Link.

MORE EQUIPMENT TO BRING YOU SUCCESS

Standard equipment



8" TouchIT user interface: 4 tabs, each with 8 beverage buttons.

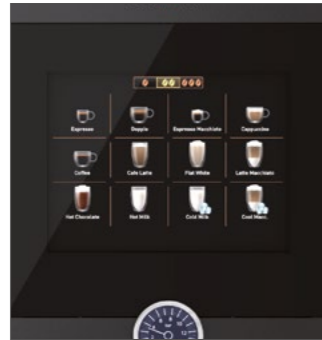

8" TouchIT user interface: Up to 12 buttons, e.g. for self-service.



One grinder with bean hopper for 1200 grams of coffee beans.



Hot water outlet for the preparation of tea.



Animated user support **visualises important processes and simplifies operation.**



USB stick easily accessible for convenient data backup and software updates.



Height-adjustable outlet 65 to 185 mm for single and/or double dispensing.

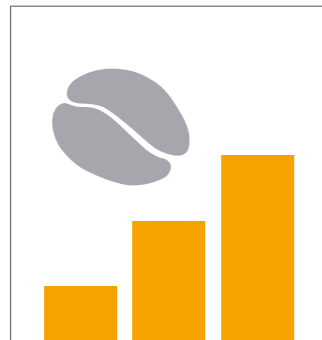

Barista key for setting flavour intensity.



Integrated grounds container for approx. 60-70 grounds cakes.



Digital manometer displays the brewing pressure and underlines the athletic design.

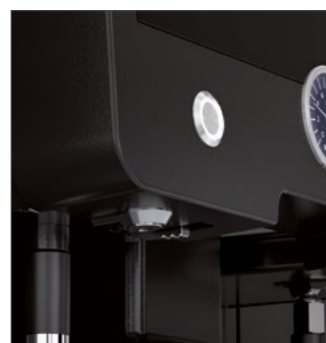

Lockable front panel with central locking for easy removal of containers.



Lockable bean hoppers and powder containers prevent access by third parties.



Cup positioning for single and double dispensing.



Uptime! descaling system Simple descaling without any interruption to service.



CONFIGURATIONS

Extension possibilities



Best Foam™ milk system for the preparation of barista-quality coffee-and-milk specialties and milk foam.



Lockable cooling unit: can be positioned on the left or right, can also be placed under the counter with extension kit.



Second grinder with bean hopper for 1200 grams of coffee beans.



Powersteam for manual milk frothing and heating.



Powder system with 2000-gram powder container for chocolate or topping powder.



Cleaning the mixing bowl: simply remove and reinsert for exceptionally easy cleaning.



Self-kit: hot water dispensing via central, height-adjustable outlet with cup positioning aid.

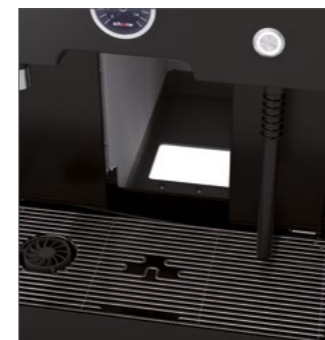

Under-counter grounds disposal is quick and easy to integrate.



Brewing accelerator for more efficiency during peak hours, enables optimum extraction time for double beverages.

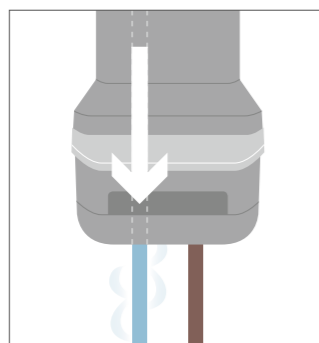

Hot water supplied via separate outlet for **preparing Americanos**.

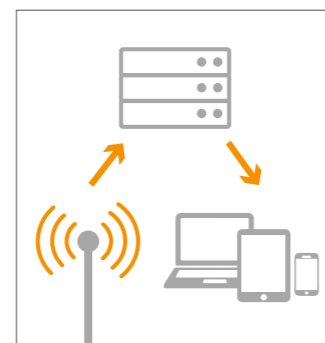

M2M Coffee Link telemetry solution provides comprehensive information for quality assurance as well as the monitoring and optimisation of individual business processes.



Milk temperature sensor for maximum food safety.

The coffee machine is currently available in the following variants.

Basic equipment with fresh milk system

Schaerer Coffee Soul with two grinders, Best Foam™ fresh milk system, side cooling unit, hot water outlet.



Full equipment

Schaerer Coffee Soul with two grinders, powder system, Best Foam™ fresh milk system, side cooling unit, hot water outlet and Powersteam.



Self-service version

Schaerer Coffee Soul with two grinders, powder system, Best Foam™ fresh milk system and side cooling unit.



CONFIGURATIONS AND TECHNICAL DATA

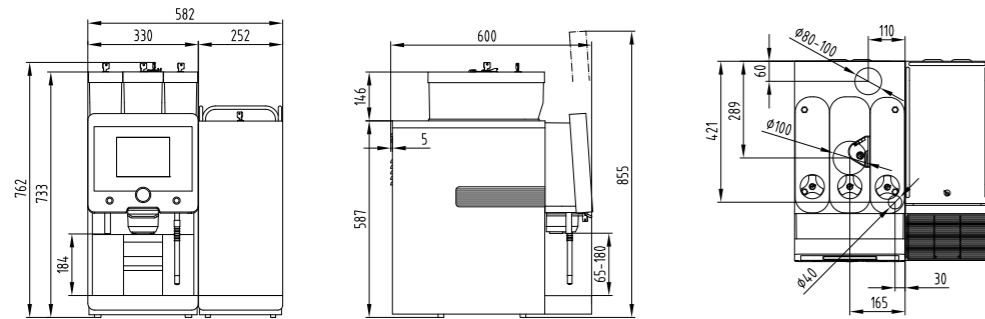

Schaerer Coffee Soul

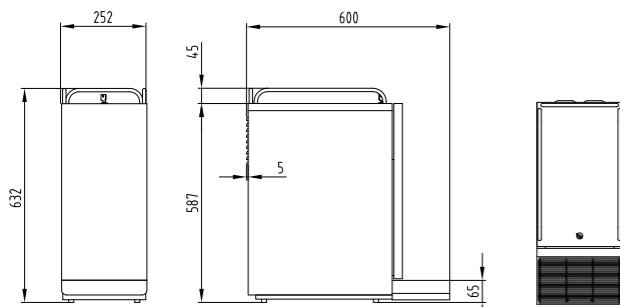

Side cooling unit

Category	Equipment and options	Schaerer Coffee Soul	
Output per day	Recommended daily output	Up to 250	
Output per hour	Beverage output per hour (coffee, espresso)	Up to 180	
Range of beverages	Espresso	s	
	Coffee/café crème	s	
	Cappuccino	o	
	Hot water	s	
	Ristretto	s	
	Small pot (250 ml)	s	
	Pot (500 ml)	s	
	Americano	o	
	White Americano	o	
	Milk coffee/latte	o	
	Latte macchiato	o	
	Espresso macchiato	o	
	Chociatto	o	
	Hot chocolate	o	
	Flat white	o	
	Instant (e.g. chai latte)	o	
	Cold milk	o	
	Hot milk	o	
Hot milk foam	o		
Cold milk foam	o		
Steam	o		
Powder-based beverages	o		
Operation and dispensing	8" touch screen user panel	s	
	Self-service mode	s	
	Number of beverages possible (programmable)	>100	
	Outlet height can be adjusted manually [mm]	65-185	
	Hot water dispensing: central or left	s	
	Additional water (Americano)	o	
	Single outlet	s	
	Double outlet	s	
Steam wand	o		
Barista key	s		
Grinders and containers	1 grinder	s	
	2 grinders	o	
	Bean hopper [g]	± 1200	
	Ground coffee inlet	s	
Boilers	Hot water boiler for coffee	s	
	Steam boiler	o	
Milk systems	Best Foam™	o	
	Side cooling unit on left or right	o	
Powder system	Powder container [g] [ml]	2000/2750	
	Chocolate (1 x Choco powder)	o	
Steam	Powersteam	o	
Other options	Cup warmer	o	
	Brewing accelerator	o	
	Grounds container [coffee grounds cake]	60-70	
	Under-counter grounds disposal	o	
	High feet (40 mm)	o	
	M2M Coffee Link	o	
Colours	Black	s	
	Special colour	o	
Dimensions	Width [mm]	330	
	Depth [mm]	600	
	Height [mm] (with lock)	738	
	Weight [kg] (net)	Approx. 55	
Energy supply and power	1L, N, PE: 220-240 V- 50/60 Hz	2000-2400 W, 10 A, 3 x 1 mm ²	
		3000-3600 W, 16 A, 3 x 1.5 mm ²	
		6000-7000 W, 30 A, 3 x 4 mm ²	
	2L, PE: 200-220 V 2- 50/60 Hz	4700-5800 W, 25 A, 3 x 4 mm ²	
		3L, N, PE: 380-415 V 3N- 0/60 Hz	5700-6400 W, 16 A, 5 x 1.5 mm ³
		3L, PE: 200 V 3- 50/60 Hz	4700-5800 W, 20 A, 4 x 2.5 mm ²
3L, PE: 220 V 3- 50/60 Hz	5700-6100 W, 25 A, 4 x 2.5 mm ²		
Water supply and disposal	Mains water supply	s	
	Waste water outlet	s	



s Standard
o Option

Variants currently available: see configurations.

Headquarter

Schaerer AG

Allmendweg 8
4528 Zuchwil
Switzerland
info@schaerer.com
www.schaerer.com

Subsidiaries

Schaerer USA Corporation

2900 Orange Avenue, Suite 102
Signal Hill, CA 90755
USA
info@schaererusa.com
www.schaererusa.com

Schaerer Deutschland GmbH

Siechenlach 1
89173 Lonsee-Urspring
Germany
info@schaerer-gmbh.de
www.schaerer-gmbh.de

Schaerer Benelux – Guy van Bogaert

Boomsesteenweg 608
2610 Antwerpen-Wilrijk
Belgium
info@schaerer.be
www.schaerer.be

